



### Product Summary

$V_{(BR)DSS}$	$R_{DS(on)TYP}$	$I_D$
30V	2.7m $\Omega$ @10V	80A
	4.4m $\Omega$ @4.5V	

### Feature

- Split Gate Trench Technology
- Low  $R_{DS(ON)}$
- Low Gate Charge
- Low Gate Resistance
- 100% UIS Tested

### Application

- DC/DC Converter
- Motor Driving
- Power Management

### PDFN5X6-8L

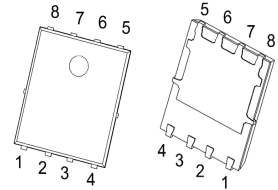

### Schematic diagram

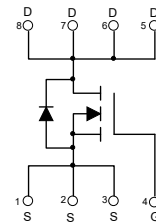

### Package Marking and Ordering Information

Part Number	Package	Marking	Packing	Reel Size	Tape Width	Qty
GPT022N03LNC	PDFN5X6-8L	T022N03L	Reel & Tape	330mm	12mm	5000pcs

### ABSOLUTE MAXIMUM RATINGS ( $T_A = 25^\circ\text{C}$ unless otherwise noted)

Parameter	Symbol	Value	Unit
Drain-Source Voltage	$V_{DS}$	30	V
Gate-Source Voltage	$V_{GS}$	$\pm 20$	V
Continuous Drain Current <sup>1</sup>	$I_D$	$T_C = 25^\circ\text{C}$	80
		$T_C = 100^\circ\text{C}$	51
Pulsed Drain Current <sup>2</sup>	$I_{DM}$	320	A
Single Pulsed Avalanche Current <sup>3</sup>	$I_{AS}$	24	A
Single Pulsed Avalanche Energy <sup>3</sup>	$E_{AS}$	144	mJ
Power Dissipation <sup>5</sup>	$P_D$	36	W
Thermal Resistance from Junction to Ambient <sup>6</sup>	$R_{\theta JA}$	55	$^\circ\text{C/W}$
Thermal Resistance from Junction to Case	$R_{\theta JC}$	3.5	$^\circ\text{C/W}$
Junction Temperature	$T_J$	150	$^\circ\text{C}$
Storage Temperature	$T_{STG}$	-55~ +150	$^\circ\text{C}$

## MOSFET ELECTRICAL CHARACTERISTICS ( $T_A = 25^\circ\text{C}$ unless otherwise noted)

Parameter	Symbol	Test Condition	Min	Type	Max	Unit
<b>Off Characteristics</b>						
Drain-Source Breakdown Voltage	$V_{(BR)DSS}$	$V_{GS} = 0V, I_D = 250\mu A$	30			V
Zero Gate Voltage Drain Current	$I_{DSS}$	$V_{DS} = 30V, V_{GS} = 0V$			1	$\mu A$
Gate-Body Leakage Current	$I_{GSS}$	$V_{GS} = \pm 20V, V_{DS} = 0V$			$\pm 100$	nA
<b>On Characteristics<sup>4</sup></b>						
Gate Threshold Voltage	$V_{GS(th)}$	$V_{DS} = V_{GS}, I_D = 250\mu A$	1	1.6	2.2	V
Drain-Source On-Resistance	$R_{DS(on)}$	$V_{GS} = 10V, I_D = 10A$		2.7	3.5	m $\Omega$
		$V_{GS} = 4.5V, I_D = 10A$		4.4	5.7	
<b>Dynamic Characteristics</b>						
Input Capacitance	$C_{iss}$	$V_{DS} = 15V, V_{GS} = 0V, f = 1MHz$		1337		pF
Output Capacitance	$C_{oss}$			460		
Reverse Transfer Capacitance	$C_{rss}$			16		
Gate Resistance	$R_g$	$V_{DS} = 0V, V_{GS} = 0V, f = 1MHz$		3.3		$\Omega$
<b>Switching Characteristics</b>						
Total Gate Charge	$Q_g$	$V_{DS} = 15V, V_{GS} = 10V, I_D = 10A$		22		nC
Gate-Source Charge	$Q_{gs}$			4.2		
Gate-Drain Charge	$Q_{gd}$			3.6		
Turn-On Delay Time	$t_{d(on)}$	$V_{DD} = 15V, V_{GS} = 10V, R_G = 3\Omega,$ $R_L = 0.75\Omega$		10		ns
Turn-On Rise Time	$t_r$			5		
Turn-Off Delay Time	$t_{d(off)}$			23		
Turn-Off Fall Time	$t_f$			5		
<b>Source-Drain Diode Characteristics</b>						
Diode Forward Voltage <sup>4</sup>	$V_{SD}$	$V_{GS} = 0V, I_S = 1A$			1.2	V

### Notes:

1. The maximum current rating is limited by package. And device mounted on a large heatsink.
2. Pulse Test: Pulse Width  $\leq 10\mu s$ , duty cycle  $\leq 1\%$ .
3. EAS condition:  $V_{DD} = 30V, V_{GS} = 10V, L = 0.5mH, R_G = 25\Omega$  Starting  $T_J = 25^\circ\text{C}$ .
4. Pulse Test: Pulse Width  $\leq 300\mu s$ , duty cycle  $\leq 2\%$ .
5. The power dissipation  $P_D$  is limited by  $T_{J(MAX)} = 150^\circ\text{C}$ . And device mounted on a large heatsink.
6. Device mounted on  $1in^2$  FR-4 board with 2oz. Copper, in a still air environment with  $T_A = 25^\circ\text{C}$ .

## Typical Characteristics

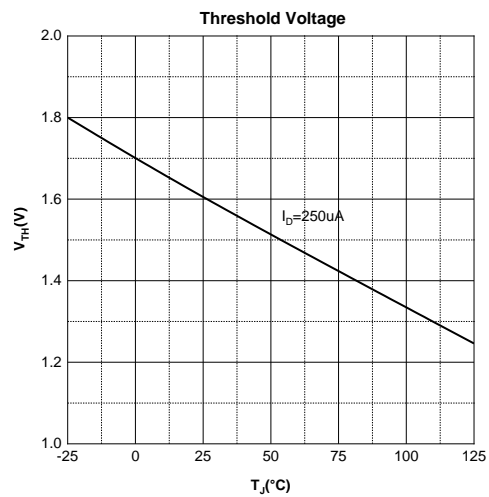
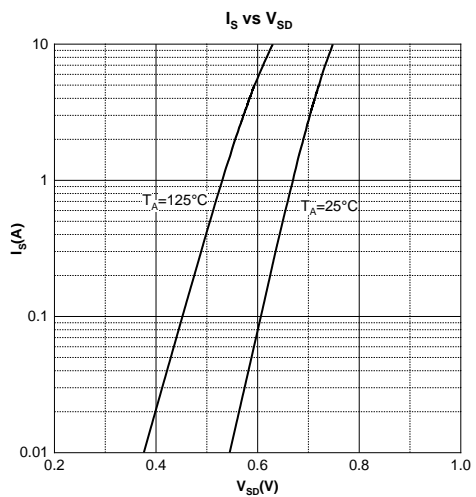
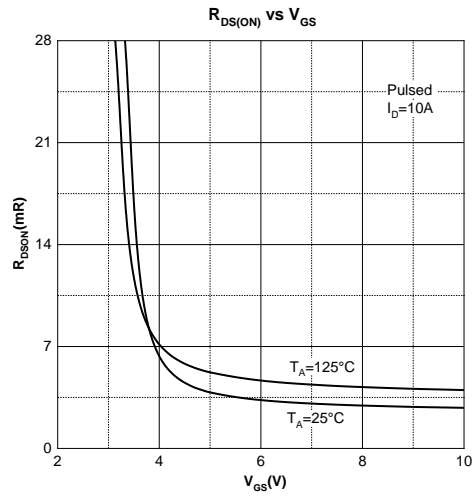
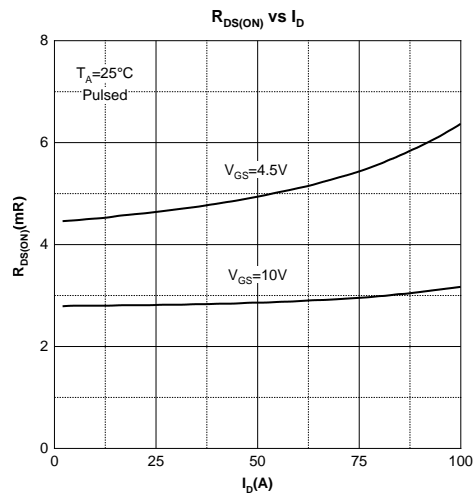
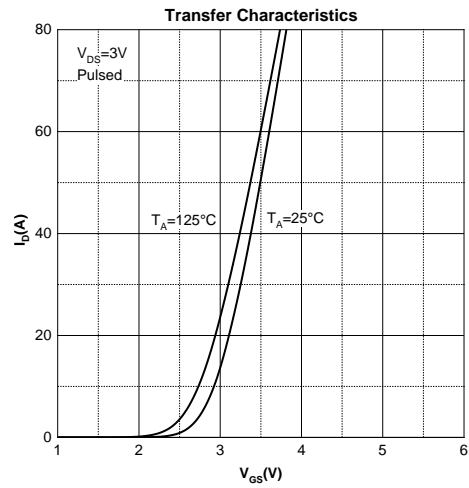
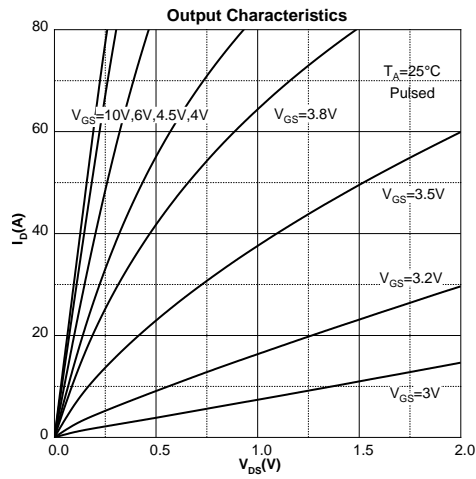

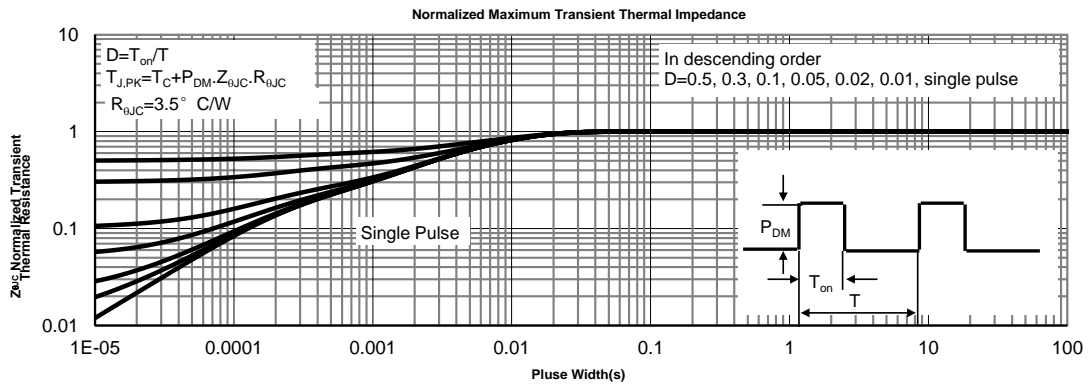
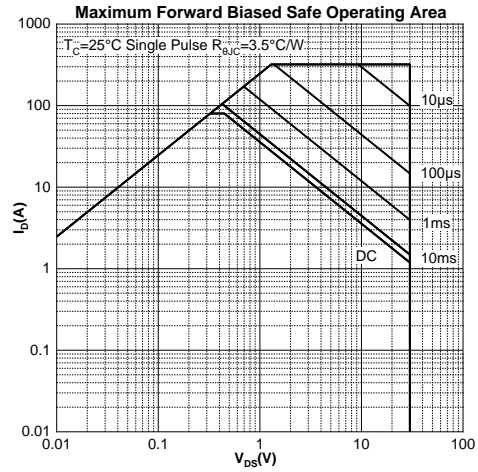
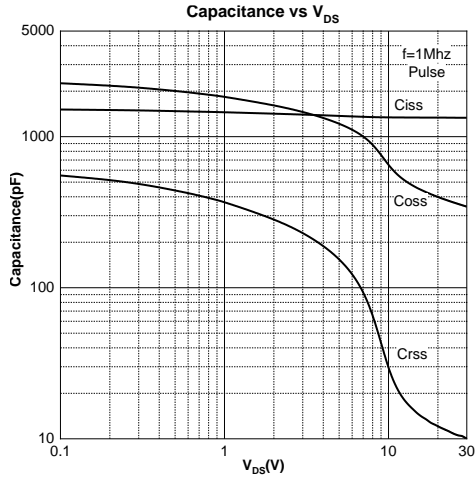

**Gate Charge Test Circuit & Waveform**

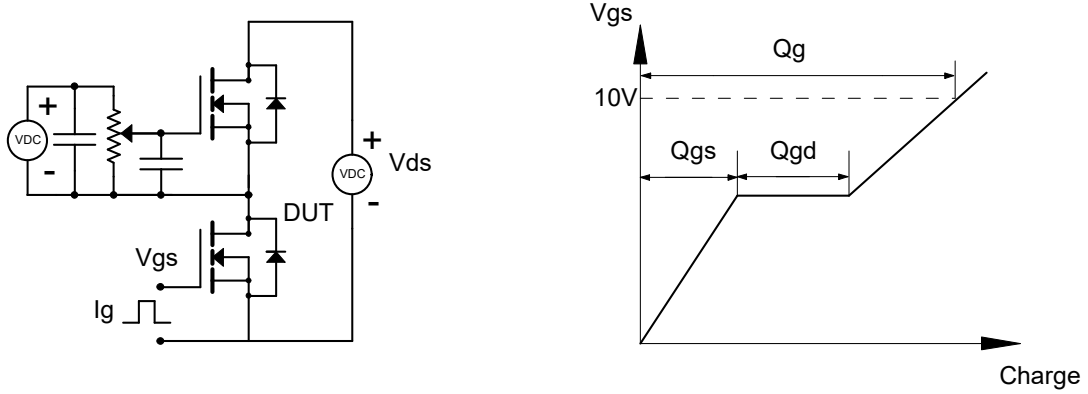

**Resistive Switching Test Circuit & Waveform**

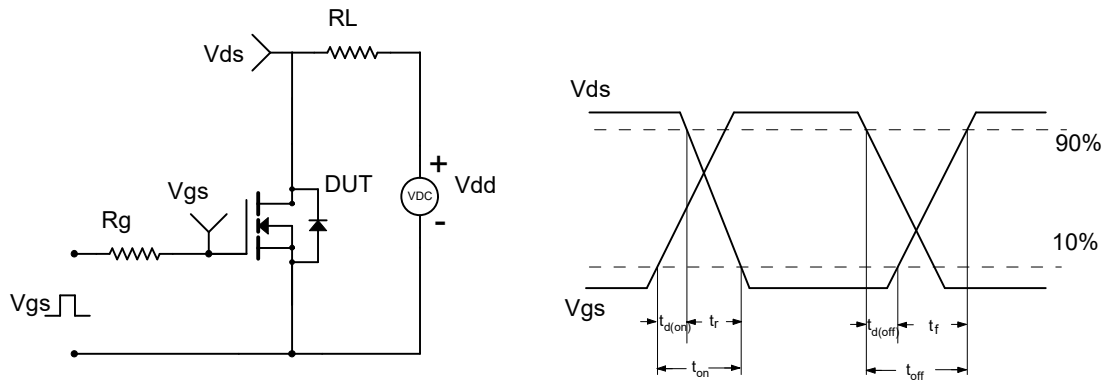

**Unclamped Inductive Switching (UIS) Test Circuit & Waveforms**

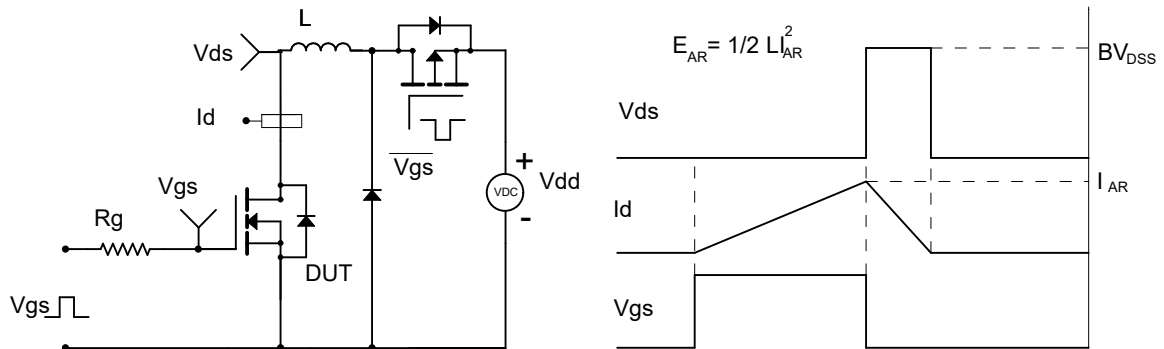

## PDFN5X6-8L Package Information

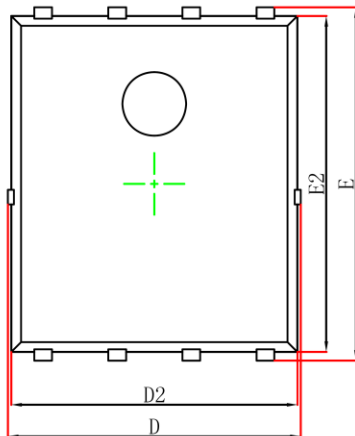

Top View  
[顶视图]

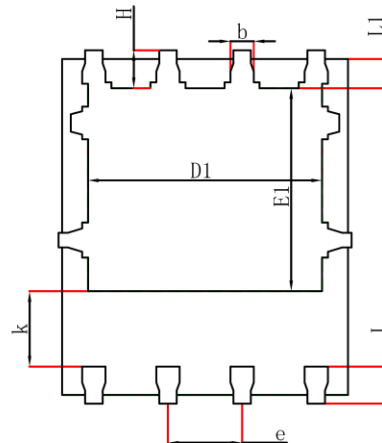

Bottom View  
[背视图]

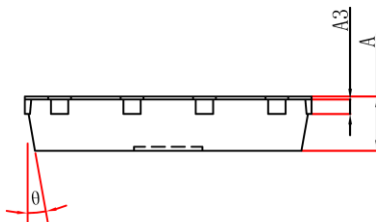

Side View  
[侧视图]

Symbol	Dimensions In Millimeters		Dimensions In Inches	
	Min.	Max.	Min.	Max.
A	0.900	1.10	0.035	0.043
A3	0.254REF		0.010REF	
D	4.700	5.260	0.185	0.207
E	5.750	6.250	0.226	0.246
D1	3.560	4.500	0.140	0.177
E1	3.180	3.660	0.125	0.144
D2	4.700	5.100	0.185	0.201
E2	5.600	6.000	0.220	0.236
k	1.100	-	0.043	-
b	0.300	0.500	0.012	0.020
e	1.270TYP		0.050TYP	
L	0.510	0.710	0.020	0.028
L1	0.424	0.576	0.017	0.023
H	0.510	0.710	0.020	0.028
$\theta$	8°	12°	8°	12°

**Attention:**

- GreenPower Electronics reserves the right to improve product design function and reliability without notice.
- Any and all semiconductor products have certain probability to fail or malfunction, which may result in personal injury, death or property damage. Customer are solely responsible for providing adequate safe measures when design their systems.
- GreenPower Electronics products belong to consumer electronics or other civilian electronic products.